

SIZE IN MILLIMETRS

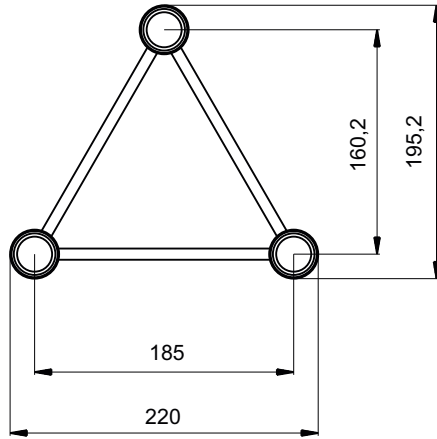

SIZE IN INCHES

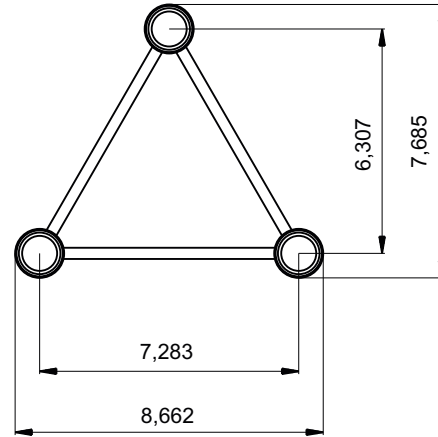

SPECIFICATIONS

| | |
|--------|-----------------------|
| TUBES | 35x2 (1.4 x 0.08inch) |
| BRACES | 8mm (0.3inch) |
| ALLOY | EN-AW 6060 T66 |



STRAIGHT SEGMENT LENGTHS

| CODE | LENGTH | | WEIGHT | |
|----------|--------|---------|--------|----------|
| FT23-50 | 0.5m | 1.64ft | 1.4kg | 3.04lbs |
| FT23-75 | 0.75m | 2.46ft | 2.1kg | 4.58lbs |
| FT23-100 | 1m | 3.28ft | 2.5kg | 5.50lbs |
| FT23-125 | 1.25m | 4.10ft | 3.2kg | 6.97lbs |
| FT23-150 | 1.5m | 4.92ft | 3.6kg | 7.96lbs |
| FT23-200 | 2m | 6.56ft | 4.8kg | 10.54lbs |
| FT23-250 | 2.5m | 8.20ft | 5.9kg | 12.99lbs |
| FT23-300 | 3m | 9.84ft | 7.0kg | 15.46lbs |
| FT23-325 | 3.25m | 10.66ft | 7.8kg | 17.22lbs |
| FT23-350 | 3.5m | 11.48ft | 8.2kg | 18.12lbs |
| FT23-375 | 3.75m | 12.30ft | 8.9kg | 19.71lbs |
| FT23-400 | 4m | 13.12ft | 9.3kg | 20.47lbs |

LOADING TABLES

| | 2m | 3m | 4m | 6m | 8m | 10m |
|-----------------------|---------------|---------------|----------------|----------------|----------------|----------------|
| Distrib. Load [kg/m] | 175 | 114 | 64 | 27 | 14 | 8 |
| Deflection [mm] | 1.5 | 4.9 | 8.9 | 20.1 | 36 | 56.8 |
| Point load [kg] | 262 | 171 | 127 | 81 | 56 | 41 |
| Deflection [mm] | 1.8 | 4 | 7.2 | 16.5 | 30 | 48.3 |
| | 6.56ft | 9.84ft | 13.12ft | 19.68ft | 26.24ft | 32.81ft |
| Distrib. Load [lb/ft] | 117.6 | 76.6 | 43 | 18.1 | 9.4 | 5.4 |
| Deflection [inch] | 0.1 | 0.2 | 0.4 | 0.8 | 1.4 | 2.2 |
| Point load [lb] | 577.7 | 377.1 | 280 | 178.6 | 123.5 | 90.4 |
| Deflection [inch] | 0.1 | 0.2 | 0.3 | 0.6 | 1.2 | 1.9 |