

### SIZE IN MILLIMETRS

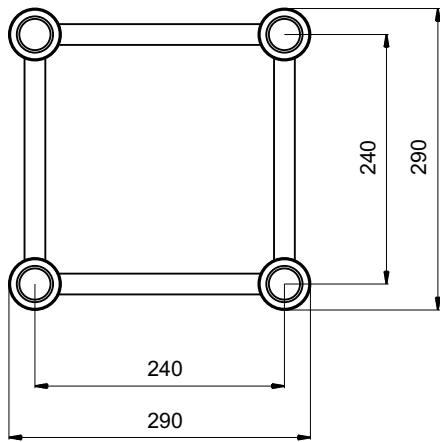

### SIZE IN INCHES

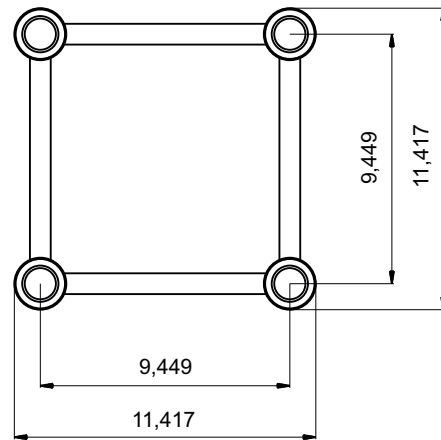

### SPECIFICATIONS

TUBES	50x2mm (2 x 0.08inch)
BRACES	16x2mm (0.63 x 0.08inch)
ALLOY	EN-AW 6082 T6



### STRAIGHT SEGMENT LENGTHS

CODE	LENGTH		WEIGHT	
	m	ft	kg	lbs
PT34-50	0.5m	1.64ft	3.4kg	7.59lbs
PT34-75	0.75	2.46ft	4.5kg	9.92lbs
PT34-100	1m	3.28ft	5.7kg	12.48lbs
PT34-150	1.5m	4.92ft	7.9kg	17.33lbs
PT34-200	2m	6.56ft	10.1kg	22.18lbs
PT34-250	2.5m	8.2ft	12.5kg	27.47lbs
PT34-300	3m	9.84ft	14.5kg	31.88lbs
PT34-350	3.5m	11.48ft	16.7kg	36.74lbs
PT34-400	4m	13.12ft	18.9kg	41.59lbs
PT34-450	4.5m	14.76ft	21.1kg	46.44lbs
PT34-500	5m	16.4ft	23.3kg	51.29lbs

### LOADING TABLES

	2 m	4 m	6 m	8 m	10 m	12 m
Distrib. Load [kg/m]	785	390	229	130	81	53
Deflection [mm]	1.4	10.8	32.5	59.3	92.5	130.3
Point load [kg]	1570	961	688	520	406	321
Deflection [mm]	2.2	10.7	26.2	47.9	75.1	106.6
	6.56 ft	13.12 ft	19.68 ft	26.24 ft	32.81 ft	37.37 ft
Distrib. Load [lb/ft]	527.6	262.1	153.9	87.4	54.4	35.6
Deflection [inch]	0.1	0.4	1.3	2.3	3.6	5.1
Point load [lb]	3461.9	2119	1517	1146.6	895.2	707.8
Deflection [inch]	0.1	0.4	1	1.9	3	4.2