

SIZE IN MILLIMETRS

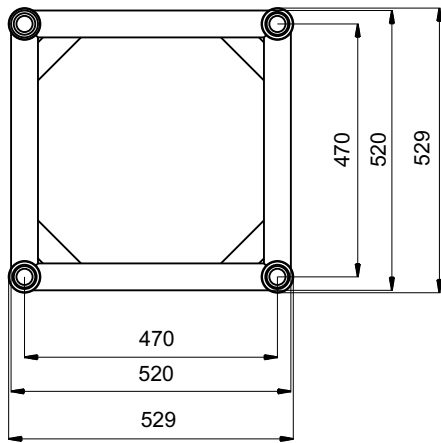

SIZE IN INCHES

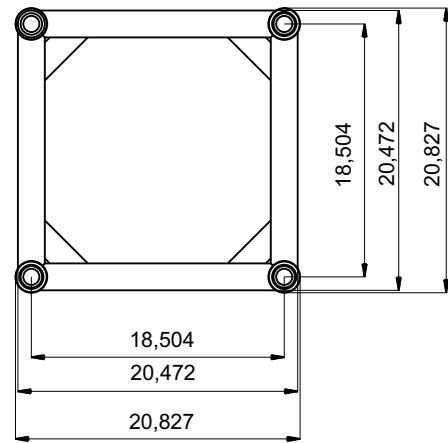

SPECIFICATIONS

TUBES	50x4mm (2 x 0.16inch)
BRACES	30x3mm (1.2 x 0.12inch)
ALLOY	EN-AW 6082 T6



STRAIGHT SEGMENT LENGTHS

CODE	LENGTH		WEIGHT	
	m	ft	kg	lbs
TT54-50	0.5m	1.64ft	11.8kg	26.05lbs
TT54-100	1m	3.28ft	17.1kg	37.74lbs
TT54-200	2m	6.56ft	28.5kg	62.84lbs
TT54-250	2.5m	8.20ft	36.2kg	79.81lbs
TT54-300	3m	9.84ft	39.7kg	87.57lbs
TT54-400	4m	13.12ft	51.3kg	113.18lbs

LOADING TABLES

	6m	8m	10m	12m	14m	16m	18m	20m
Distrib. Load [kg/m]	729	409	259	117	128	93	69	52
Deflection [mm]	16.9	30.3	47.9	69.8	95.9	123.3	153.5	186.6
Point load [kg]	2188	1635	1296	1065	895	741	618	517
Deflection [mm]	14.1	25.3	40	58.1	79.9	102.7	128	155.5
	19.7ft	26.2ft	32.8ft	39.4ft	45.9ft	52.5ft	59.1ft	65.6ft
Distrib. Load [lb/ft]	489.9	274.9	174.1	78.6	86	62.5	46.4	34.9
Deflection [inch]	0.7	1.2	1.9	2.7	3.8	4.9	6	7.3
Point load [lb]	4824.5	3605.2	2857.7	2348.3	1973.5	1633.9	1362.7	1140
Deflection [inch]	0.6	1	1.6	2.3	3.1	4	5	6.1